

# GRÅFJÄLLET

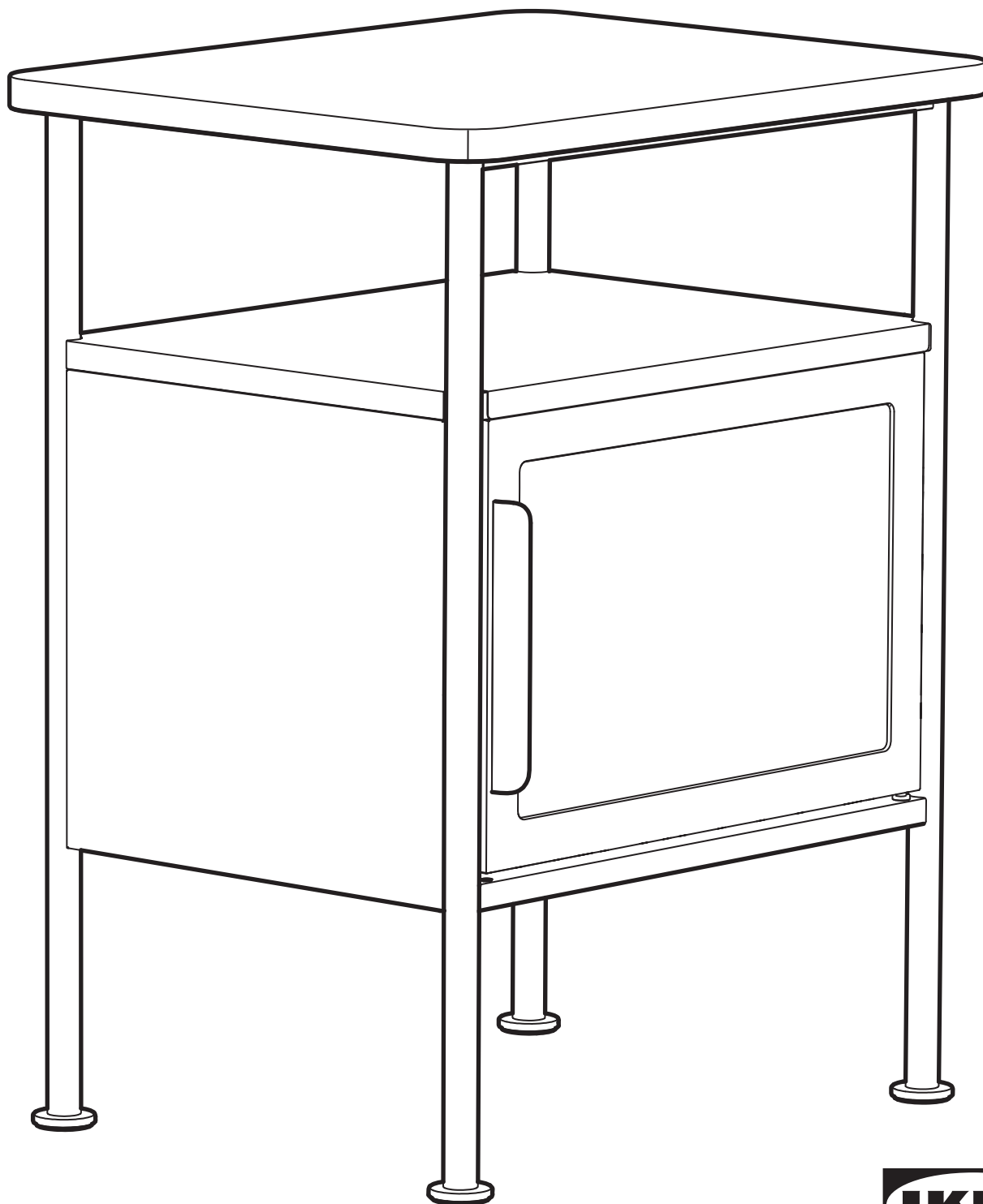

Design and Quality  
IKEA of Sweden



#### English

WARNING – Delicate table - Do not sit on the product.

WARNING – Delicate table - Do not place heavy objects on this product, maximum load 25 kg (55 lb).

#### Deutsch

ACHTUNG – Empfindlicher Tisch – Nicht auf das Produkt setzen.

ACHTUNG – Empfindlicher Tisch – Keine schweren Gegenstände auf dieses Produkt legen, maximale Belastung 25 kg (55 lb).

#### Français

ATTENTION – Table fragile - Ne pas s'asseoir sur ce produit.

ATTENTION – Table fragile - Ne rien poser de lourd sur ce produit, charge maximum 25 kg (55 lb).

#### Nederlands

WAARSCHUWING – Kwetsbare tafel - Ga niet op de tafel zitten.

WAARSCHUWING – Kwetsbare tafel - Plaats geen zware objecten op de tafel, de max. belasting is 25 kg.

#### Dansk

ADVARSEL – Skrøbeligt bord - Sid ikke på produktet.

ADVARSEL – Skrøbeligt bord - Placer ikke tunge genstande på produktet, maks. belastning fra 25 kg.

#### Íslenska

VARÚÐ – Viðkvæmt borð, ekki sitja á vörinni.

VARÚÐ – Viðkvæmt borð. Ekki leggja þunga hluti á vöruna, hámarksburðarþol 25 kg (55 lb).

#### Norsk

ADVARSEL – Delikat bord – Skal ikke sittes på.

ADVARSEL – Delikat bord – Ikke plasser tunge gjenstander på dette produktet, maks vektbelastning 25 kg (55 lb).

#### Suomi

VAROITUS – Pöytä ei kestä suurta kuormitusta. – Älä istu tuotteen päälle.

VAROITUS – Pöytä ei kestä suurta kuormitusta. – Älä aseta painavia esineitä tämän tuotteen päälle. Valmistajan määrittämä enimmäiskuormitus 25 kg.

#### Svenska

VARNING – Ömtåligt bord – Sitt inte på produkten.

VARNING – Ömtåligt bord – Placera inga tunga föremål på denna produkt, maximal belastning 25 kg (55 lb).

#### Česky

VAROVÁNÍ – Křehký stůl – Nesedějte si na výrobek.

VAROVÁNÍ – Křehký stůl – Nepokládejte na tento výrobek těžké předměty, maximální zatížení udávané výrobcem je 25 kg.

#### Español

ADVERTENCIA - Mesa frágil - No te sientes encima del producto.

ADVERTENCIA - Mesa frágil - No coloques objetos pesados encima de este producto, carga máxima: 25 kg.

#### Italiano

AVVERTENZA: tavolo delicato, non sederti sul prodotto.

AVVERTENZA: tavolo delicato, non posizionare oggetti pesanti sul prodotto, carico massimo 25 kg.

#### Magyar

FIGYELEM - Sérülékeny asztal - Ne ülj rá!

FIGYELEM - Sérülékeny asztal - Ne helyezz rá nehéz tárgyakat, maximális terhelés: 25 kg.

#### Polski

OSTRZEŻENIE – Delikatny stół – nie siadaj na produkcie.

OSTRZEŻENIE – delikatny stół – nie stawiaj na produkcie ciężkich przedmiotów; maksymalne obciążenie to 25 kg (55 lb).

#### Eesti

HOIATUS – Õrn laud – Ära istu tootel.

HOIATUS – Õrn laud – Ära aseta sellele tootele raskeid esemeid, maksimumkoormus on 25 kg.

#### Latviešu

BRĪDINĀJUMS! Trausls materiāls. Uz šīs precēs nedrīkst sēdēt!

BRĪDINĀJUMS! Trausls materiāls. Nenovietoj uz šīs precēs smagus objektus. Ražotāja noteiktā maksimālā slodze: 25 kg.

#### Lietuvių

ĮSPĖJIMAS – Lengvai pažeidžiamas stalas – nesėdėkite ant šio gaminio.

ĮSPĖJIMAS – Lengvai pažeidžiamas stalas – nedėkite sunkių daiktų ant šio gaminio, gamintojo nurodyta didžiausia apkrova 25 kg.

#### Portugues

AVISO – Mesa delicada – Não sentar no produto.

AVISO – Mesa delicada – Não colocar objetos pesados sobre este produto. A carga máxima suportada é de 25kg.

#### Română

AVERTISMENT – Masă nerezistentă – Nu te așeza.

AVERTISMENT – Masă nerezistentă – Sarcină max. 25 kg; nu așeza obiecte grele pe acest produs.

#### Slovensky

UPOZORNENIE – Krehký stôl – na výrobok si, prosím, nesadajte.

UPOZORNENIE – Krehký stôl – Na tento výrobok neumiestňujte ťažké predmety, nosnosť je maximálne 25 kg.

#### Български

ВНИМАНИЕ - Деликатна маса - Не сядайте върху продукта.

ВНИМАНИЕ - Деликатна маса - Не поставяйте тежки вещи върху продукта на максимално натоварване 25 кг (55 lb).

#### Hrvatski

UPOZORENJE – Krhak stol – Ne sjedati na proizvod.

UPOZORENJE – Krhak stol – Ne stavljati teške proizvode na ovaj proizvod; maksimalno opterećenje 25 kg.

#### Ελληνικά

ΠΡΟΣΟΧΗ - Ευαίσθητο τραπέζι - Μην κάθεστε πάνω στο προϊόν.

ΠΡΟΣΟΧΗ - Ευαίσθητο τραπέζι - Μην τοποθετείτε βαριά αντικείμενα στο προϊόν, μέγιστο βάρος 25 Kg.

#### Українська

ЗАСТЕРЕЖЕННЯ – Делікатний стіл – Не сідайте на виріб.

ЗАСТЕРЕЖЕННЯ – Делікатний стіл – Не розміщуйте важкі предмети на цьому виробі, максимальне навантаження: 25 кг.

#### Srpski

UPOZORENJE – Osetljiv sto – Nemoj sedati na proizvod

UPOZORENJE – Osetljiv sto – Nemoj stavljati teške predmete na ovaj proizvod, maksimalna nosivost 25 kg.

#### Slovenščina

POZOR – Občutljiva miza – Izdelek ni primeren za sedenje.

POZOR – Občutljiva miza – Na ta izdelek ne polagaj težkih predmetov. Največja dovoljena obremenitev: 25 kg.

#### Türkçe

UYARI - Hassas masa - Ürünün üzerine oturmuyunuz.

UYARI - Hassas masa - Bu ürünün üzerine ağır nesnelere yerleştirmeyiniz, maksimum yük 25 kg (55 lb).

#### 中文

警告 - 易碎桌子 - 请勿坐在产品上。

警告 - 易碎桌子 - 请勿将重物放置在本产品上，最大承重为25公斤（55磅）。

#### 繁體

警告 - 容易損壞 - 切勿坐在桌上

警告 - 容易損壞 - 請勿在產品上放置重物，最高可承重25公斤(55磅)

#### 한국어

주의 - 제품에 앉으면 테이블이 파손될 수 있으니 앉으면 안 됩니다.

주의 - 최대 하중은 25kg(55lb)이므로 제품에 무거운 물건을 올리면 테이블이 파손될 수 있습니다.



#### 日本語

警告 - 繊細なテーブル - 上に座らないでください。

警告 - 繊細なテーブル - 上に重いものを置かないでください。最大荷重は25kgです。

#### Bahasa Indonesia

PERINGATAN - Meja halus - Jangan duduk di atas produk.

PERINGATAN - Meja halus - Jangan letakkan benda berat di atas produk ini, beban maksimum 25 kg (55 lb).

#### Bahasa Malaysia

AMARAN - Meja tidak kukuh - Jangan duduk di atas produk ini.

AMARAN - Meja tidak kukuh - Jangan letakkan objek berat di atas produk ini, beban maksimum pengilang 25 kg (55 lb).

#### عربي

تحذير - طاولة حساسة - لا تجلسي على المنتج.

تحذير - طاولة حساسة - لا تضعي أشياء ثقيلة على هذا المنتج، الحمولة القصوى 25 كجم (55 رطلاً).

#### ไทย

คำเตือน: โต๊ะไม่เหมาะกับการรับน้ำหนักมาก ห้ามนั่งบนสินค้านี้

คำเตือน - โต๊ะไม่เหมาะกับการรับน้ำหนักมาก - ห้ามวางสิ่งของหนักลงบนสินค้านี้ น้ำหนักสูงสุดที่รองรับได้ 25 กก. (55 ปอนด์)

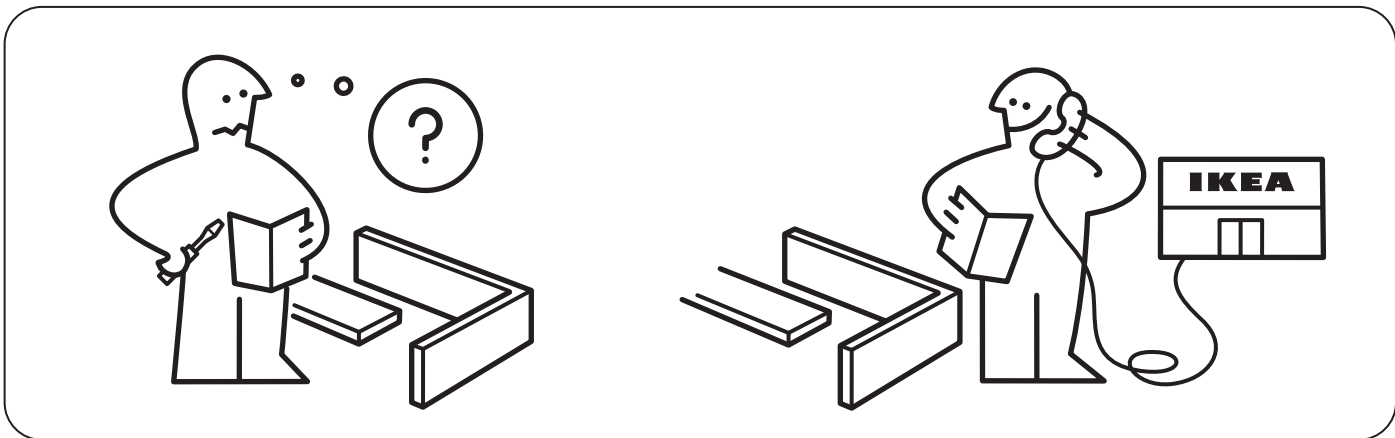
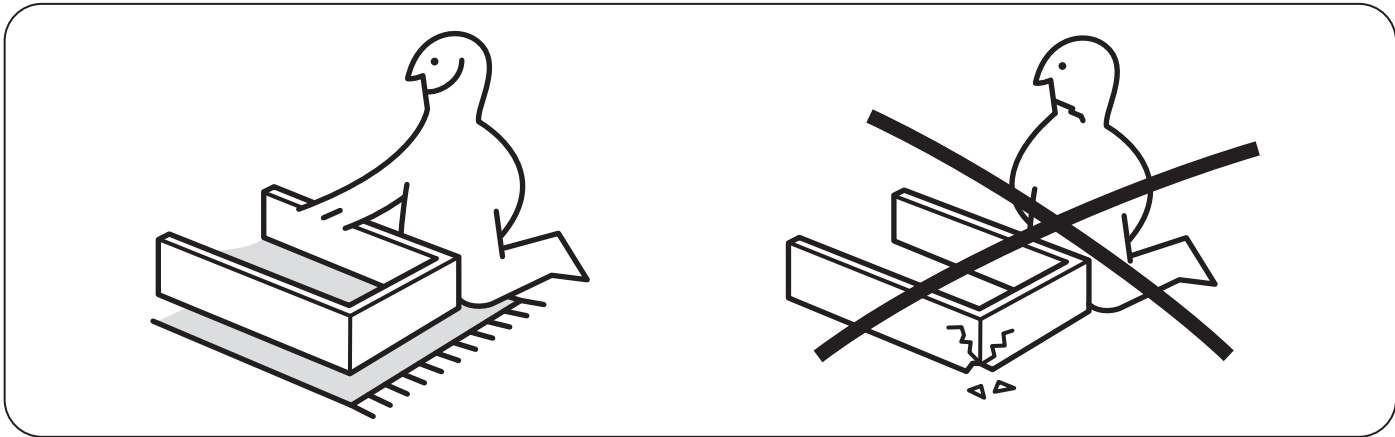
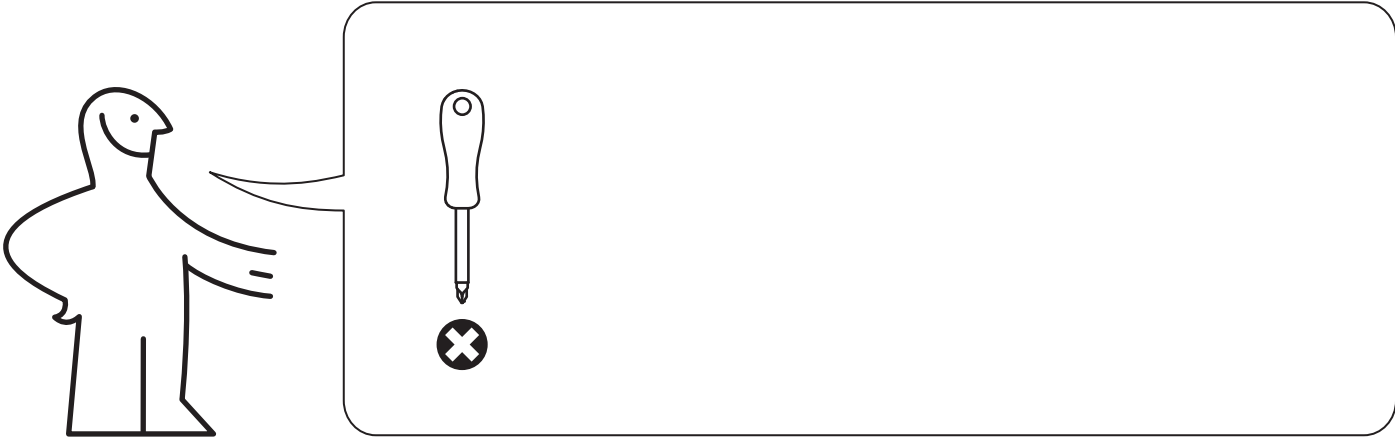

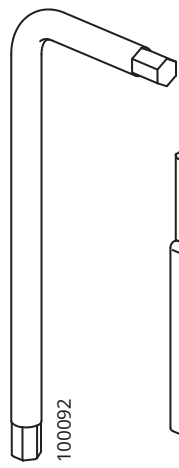

1x

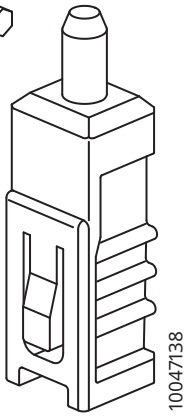

1x

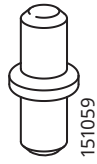

1x



4x



1x



10x

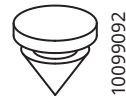

1x

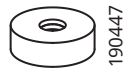

1x

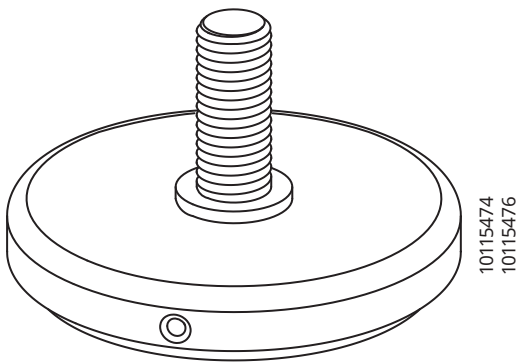

4x

1

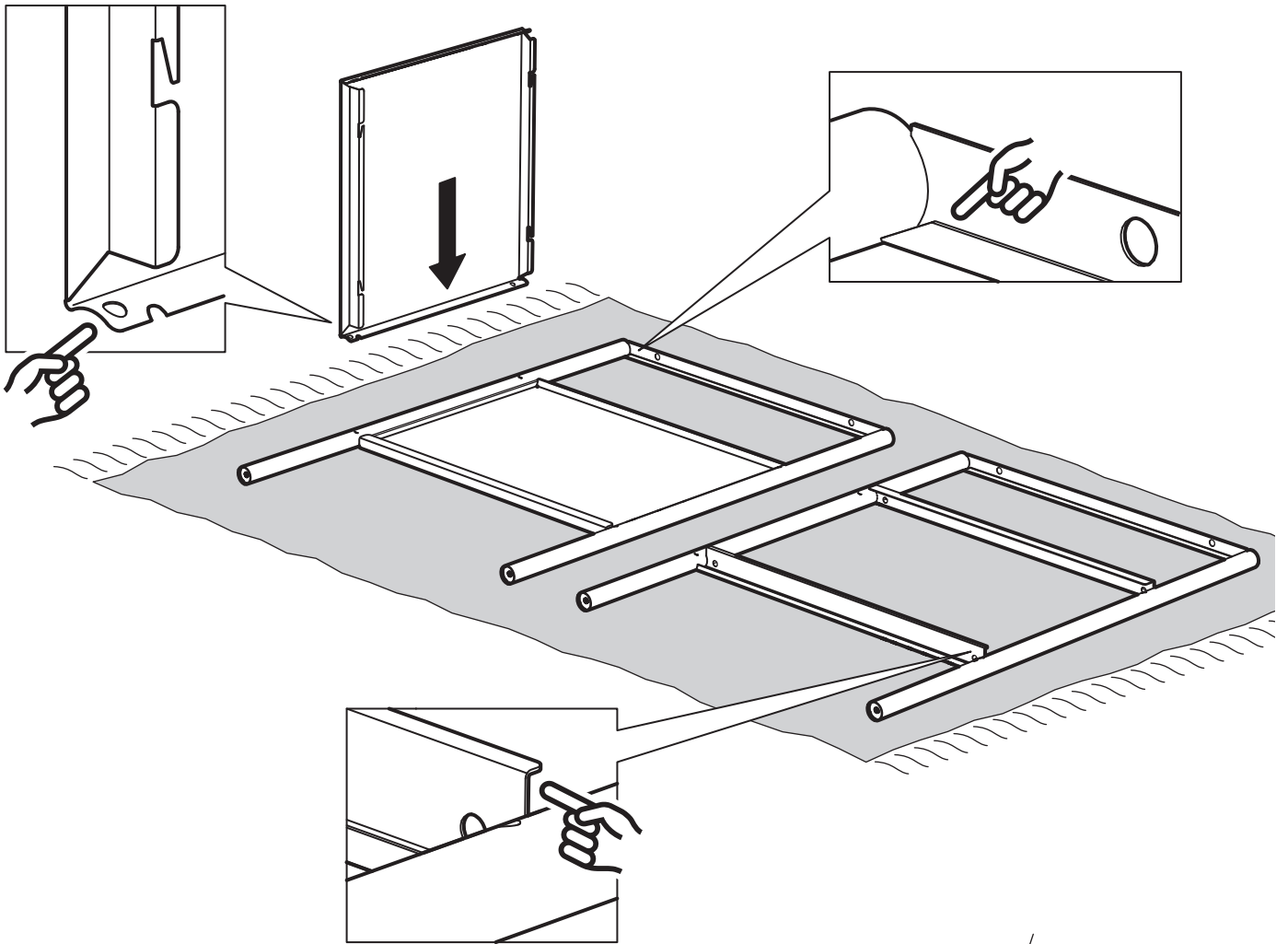

2

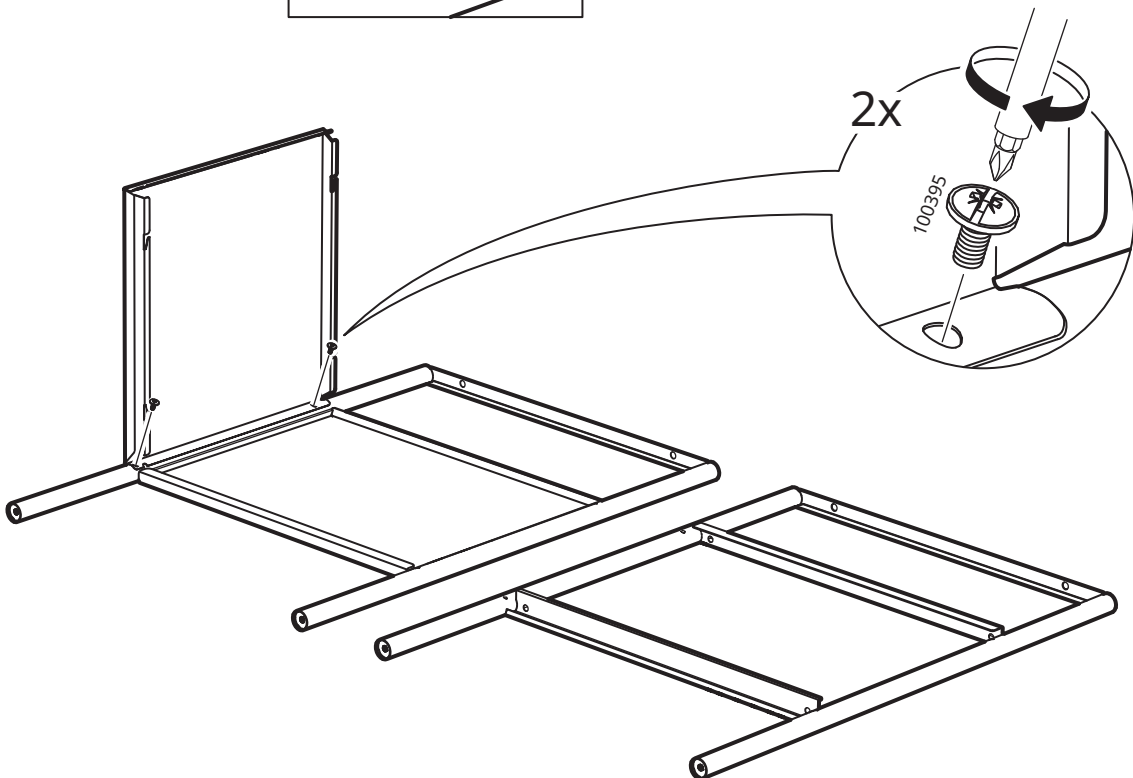

3

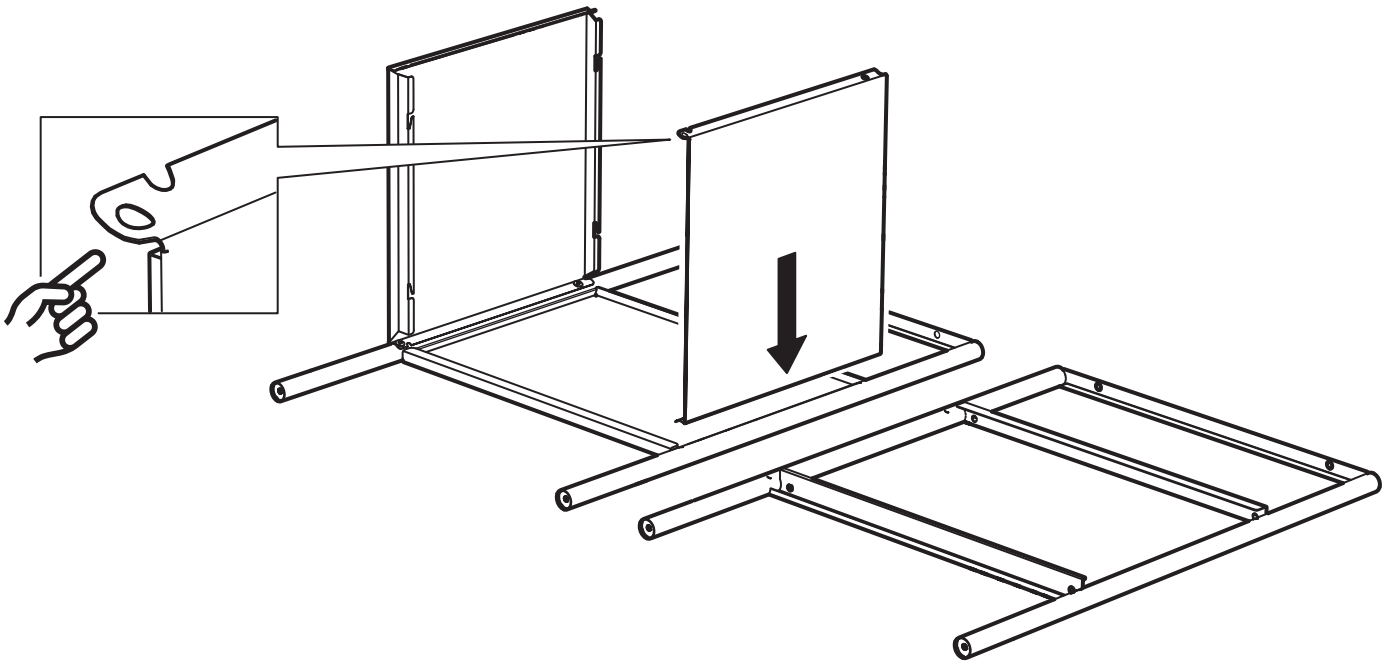

4

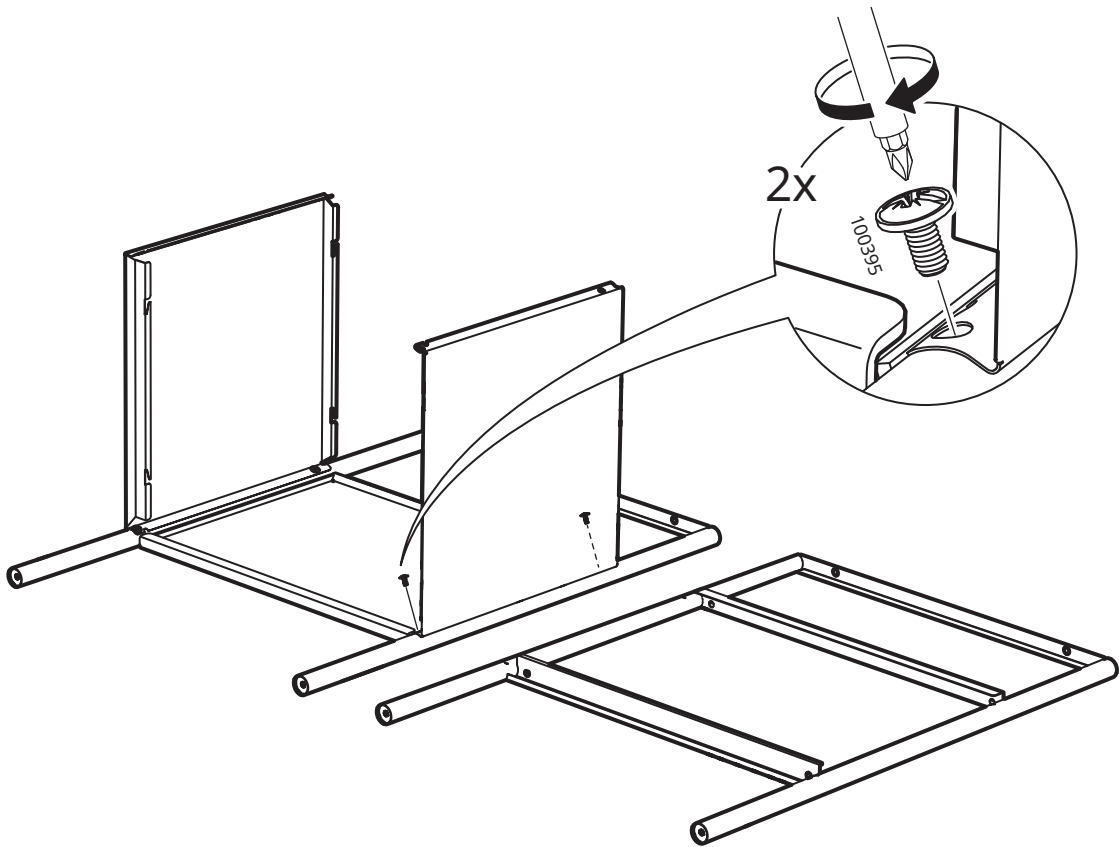

5

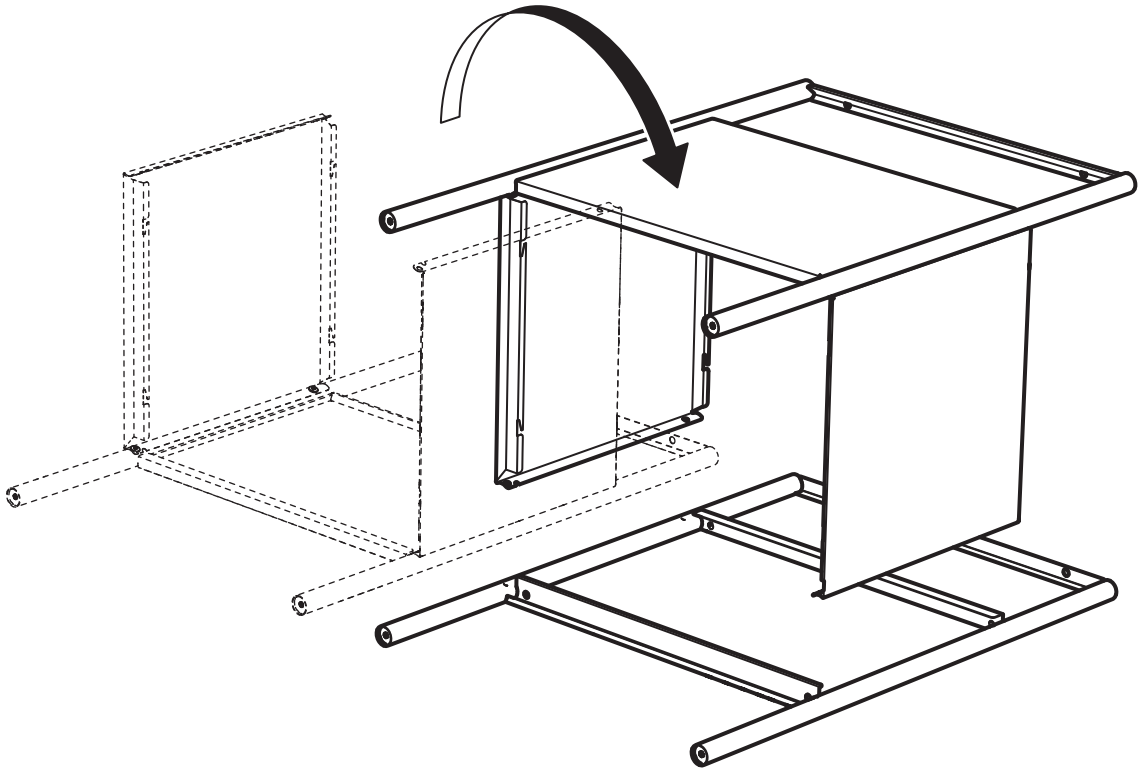

6

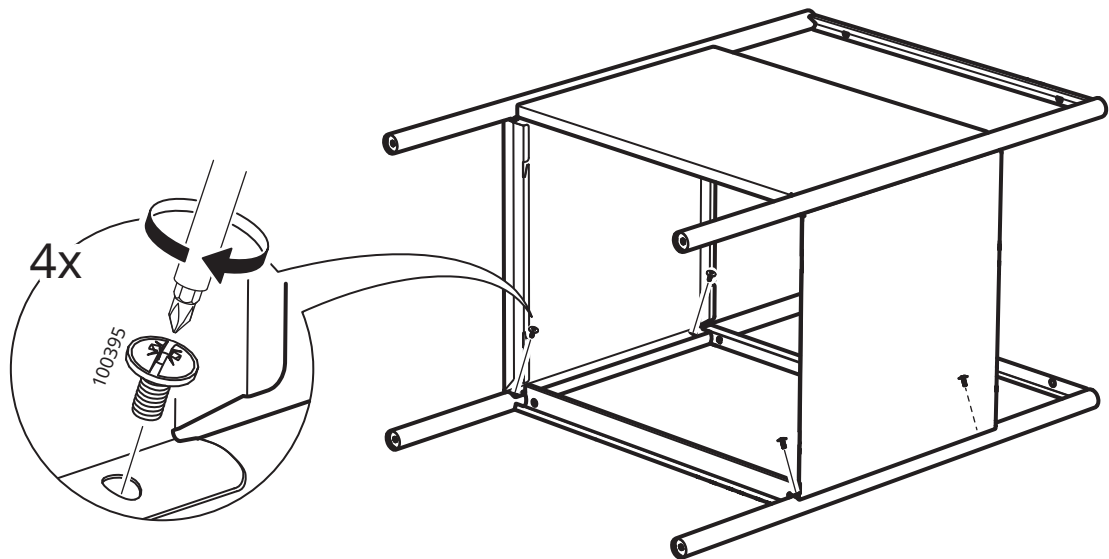



7

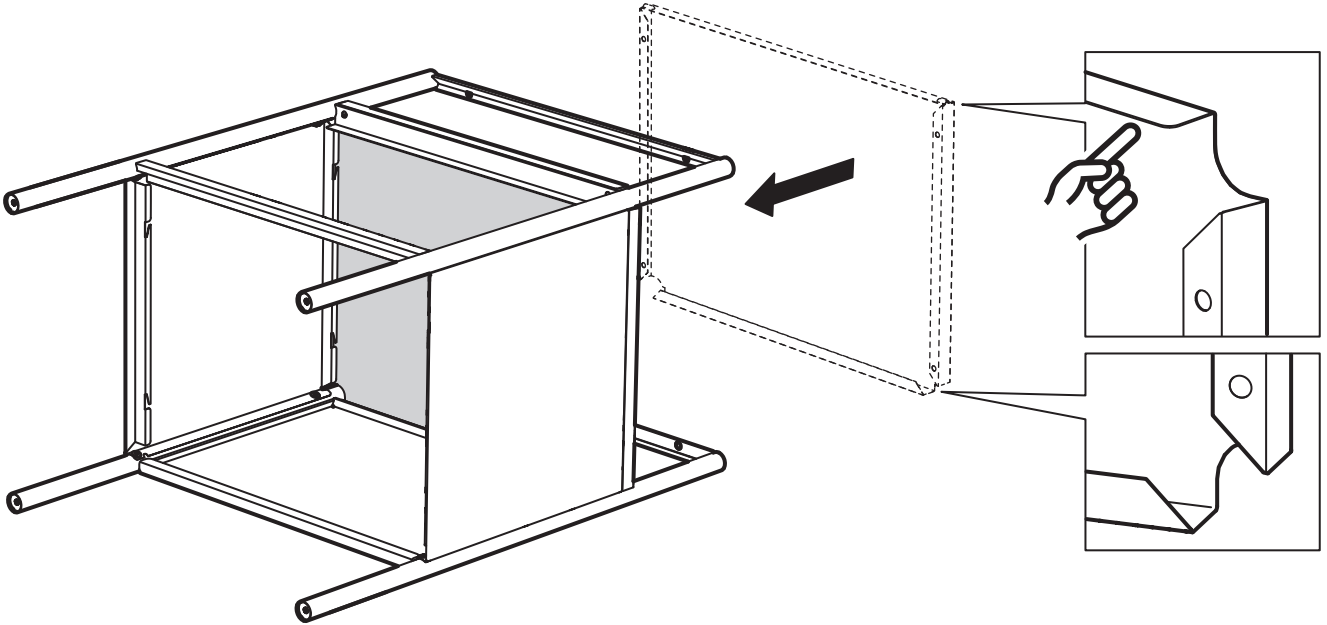
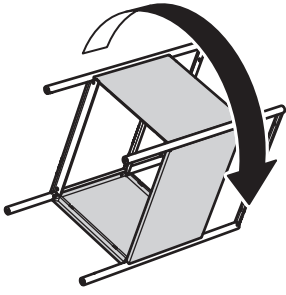

8

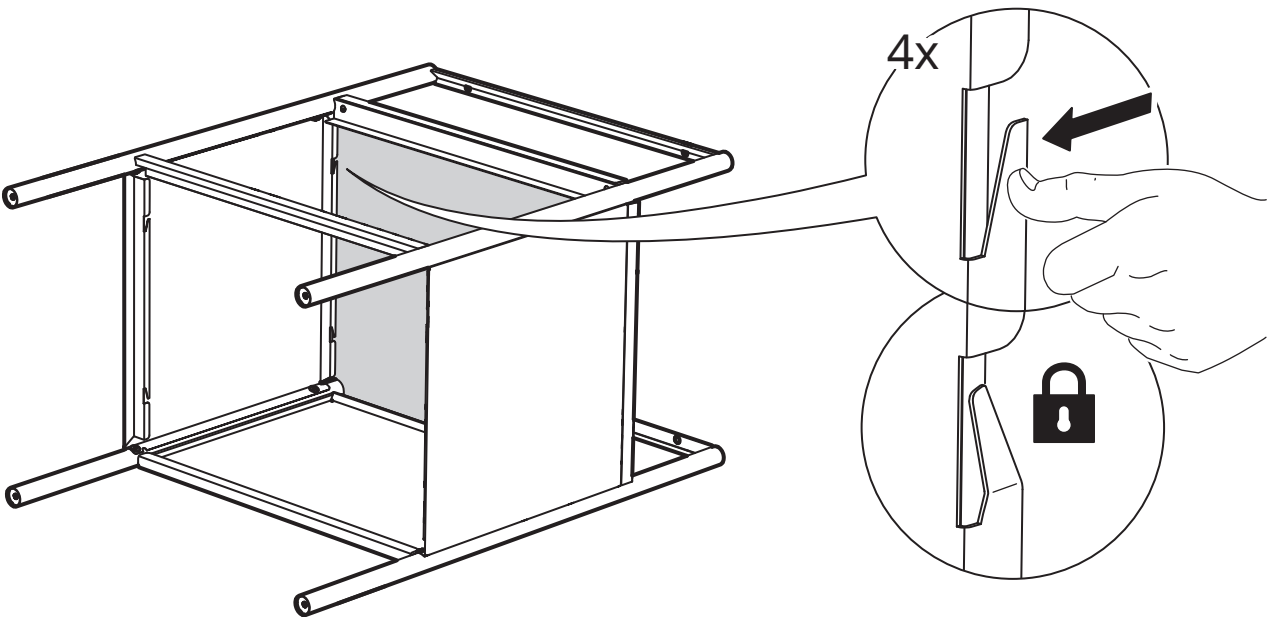

9

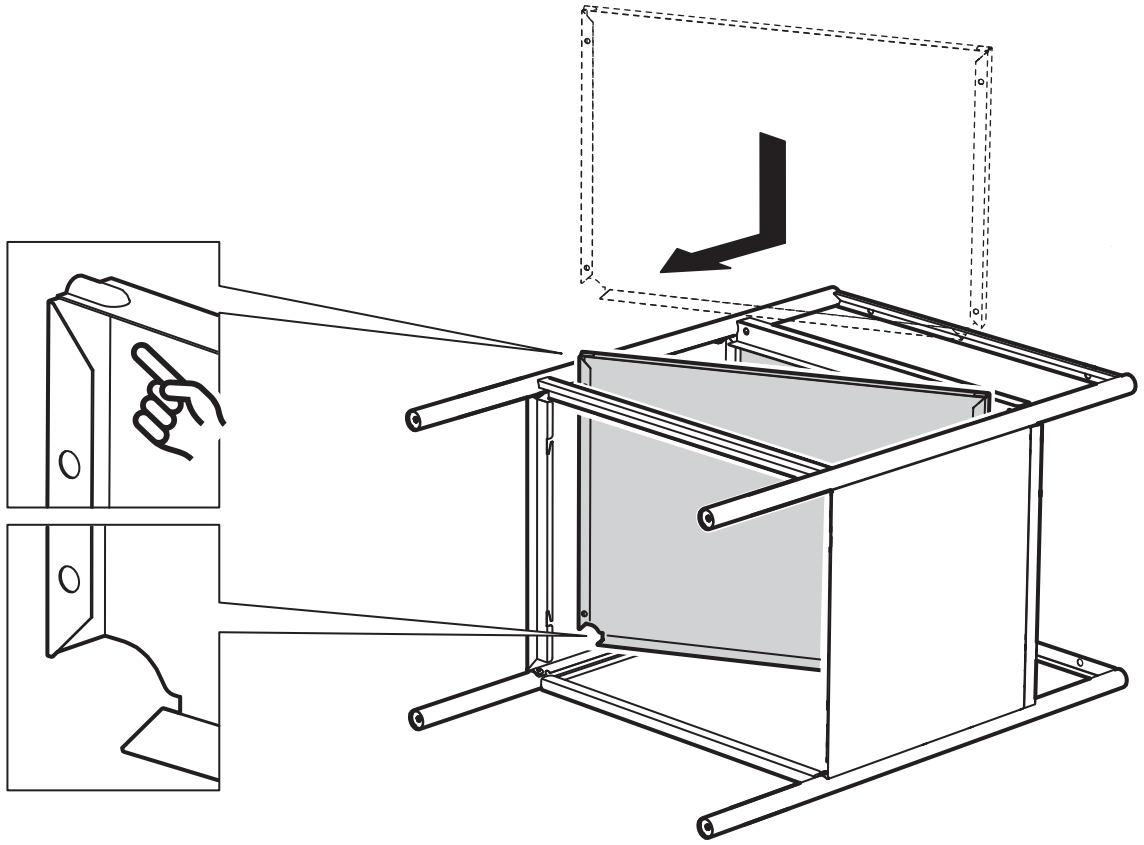

10

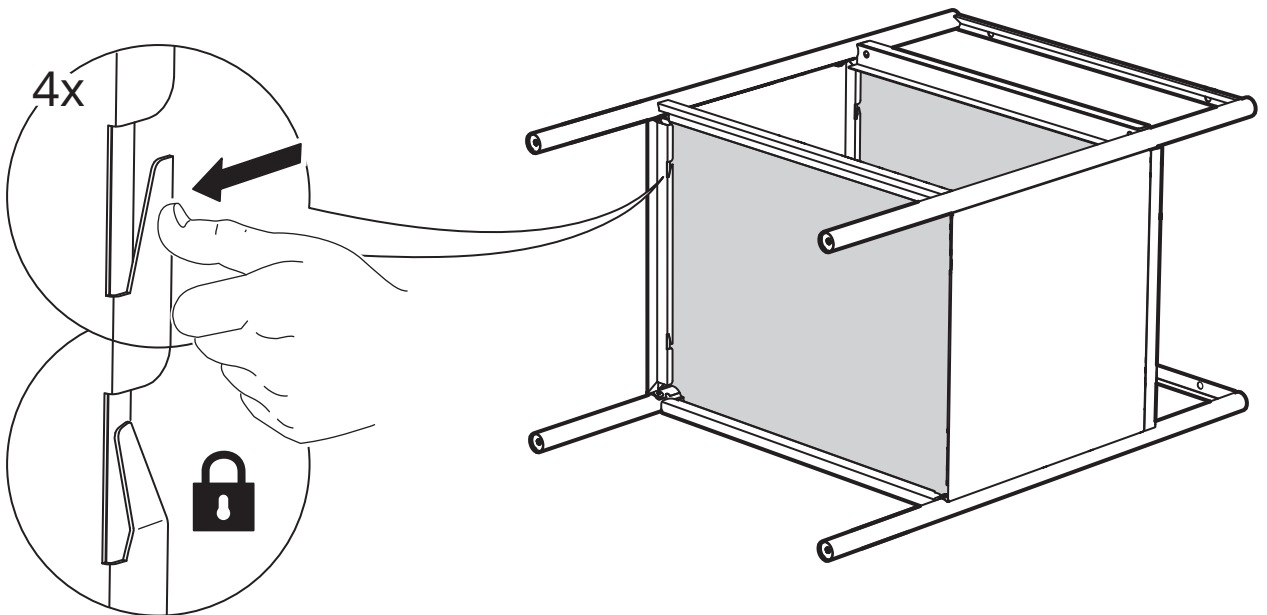

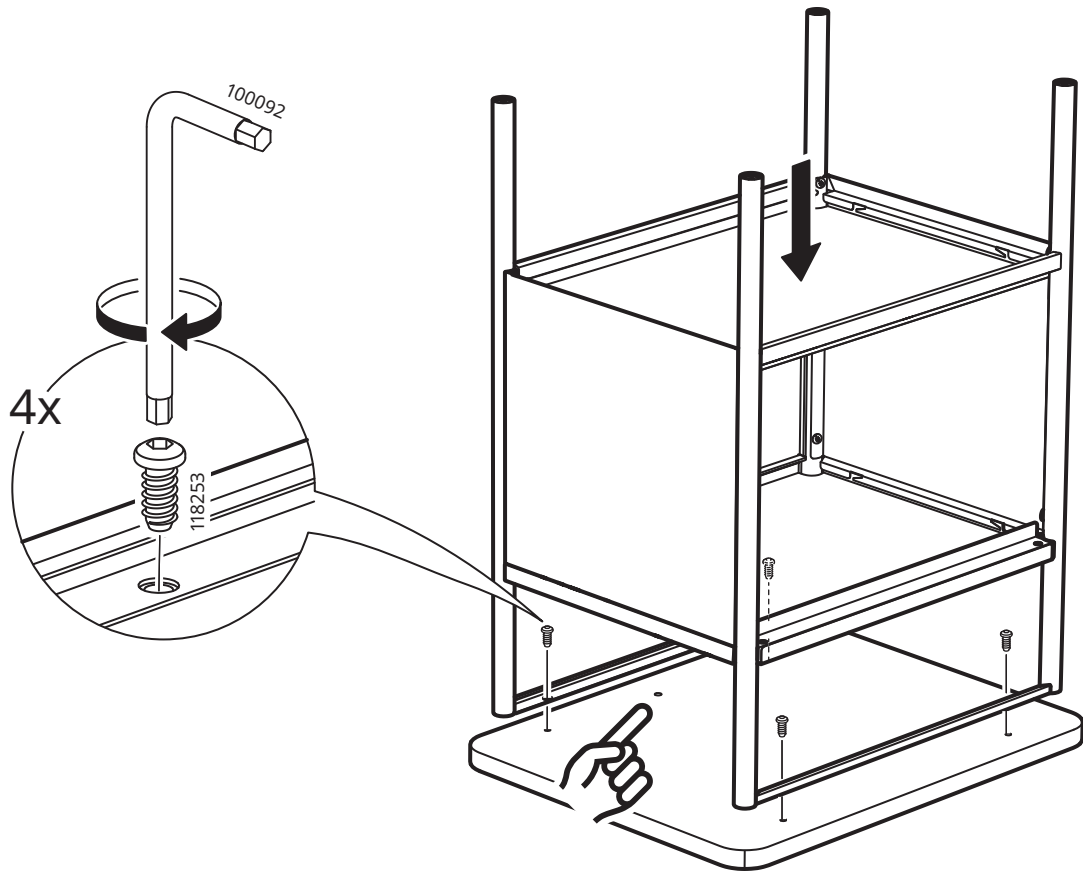

# 12

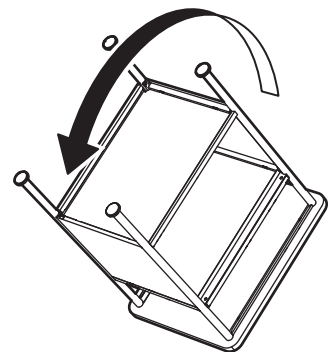
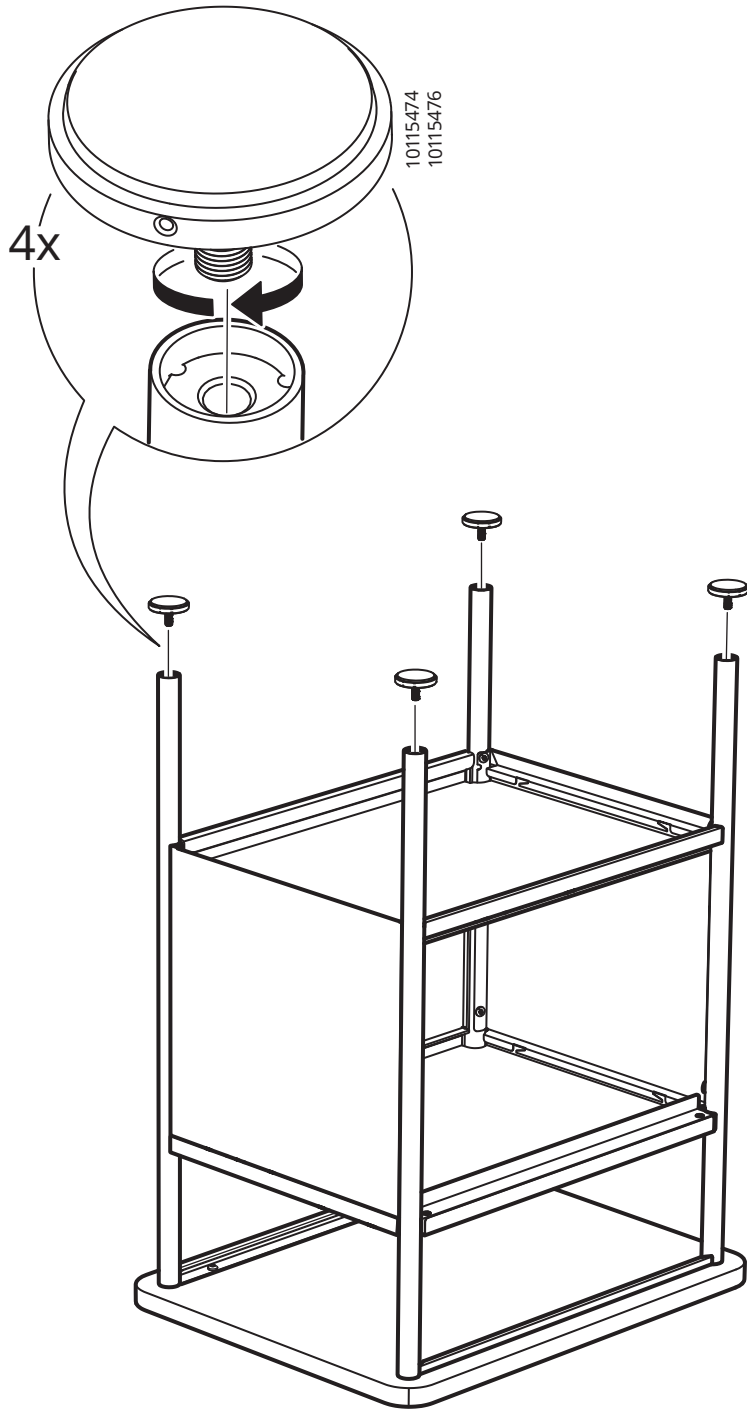

13

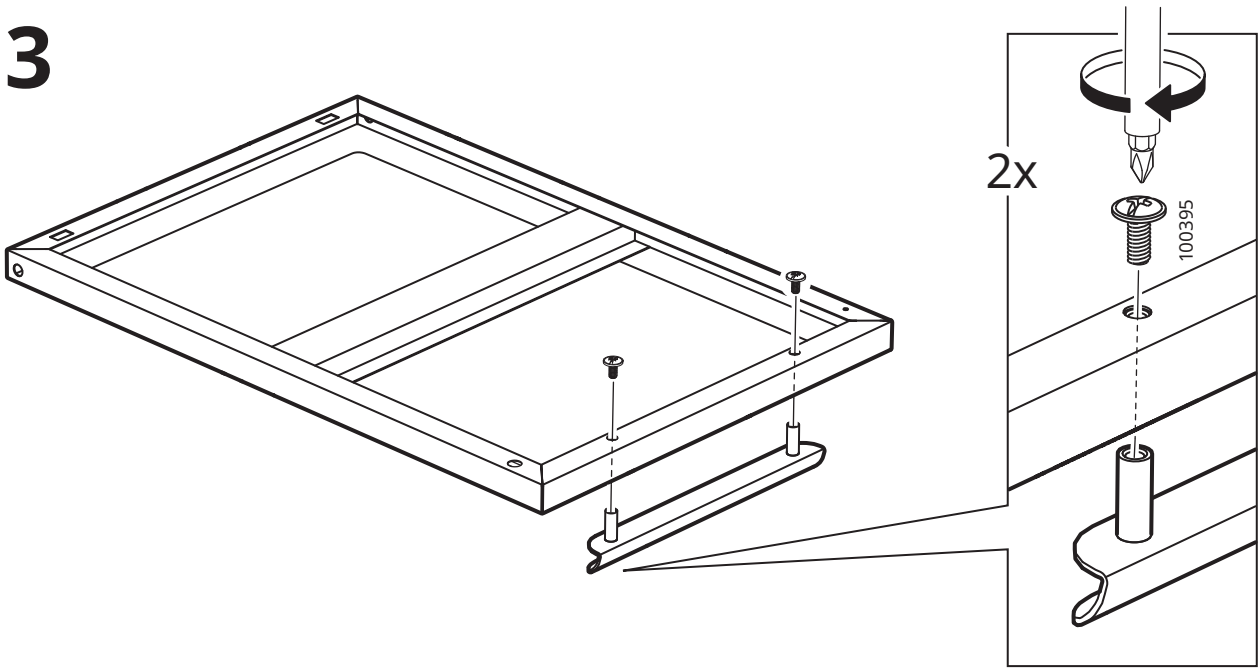

14

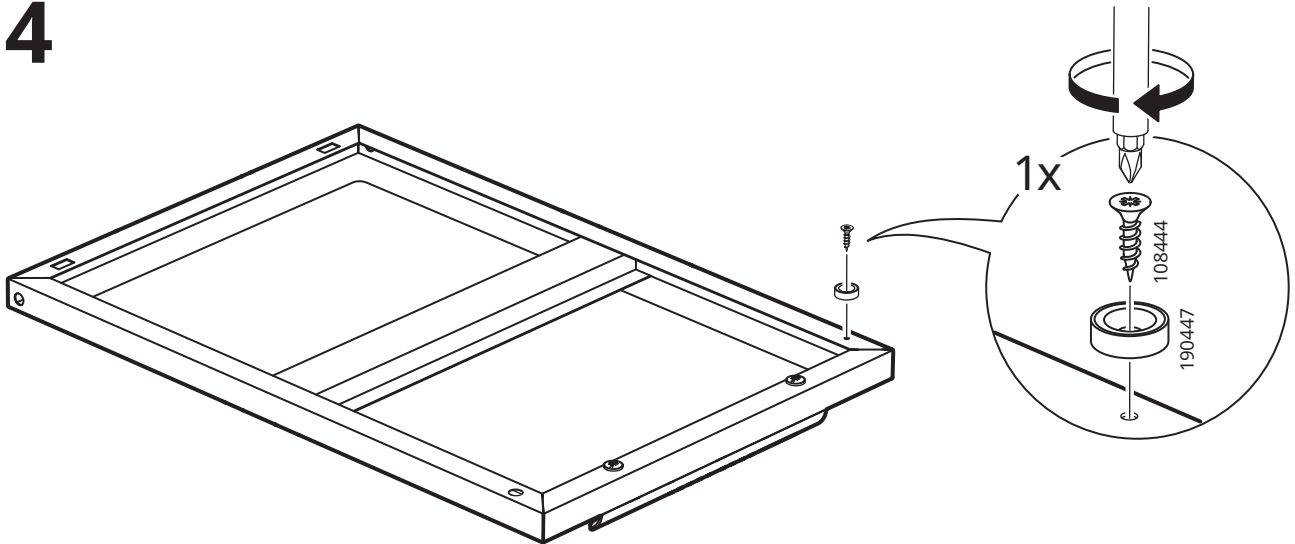

15

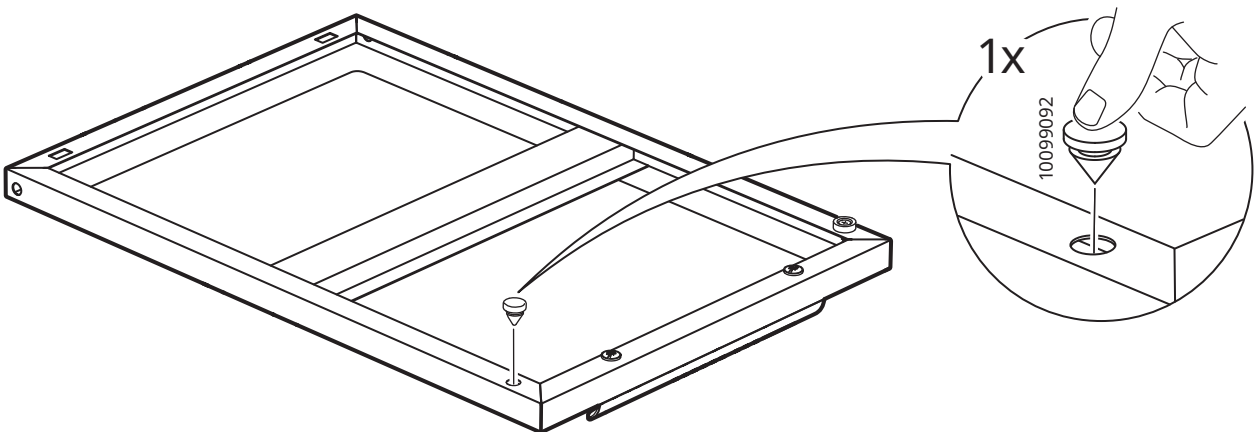

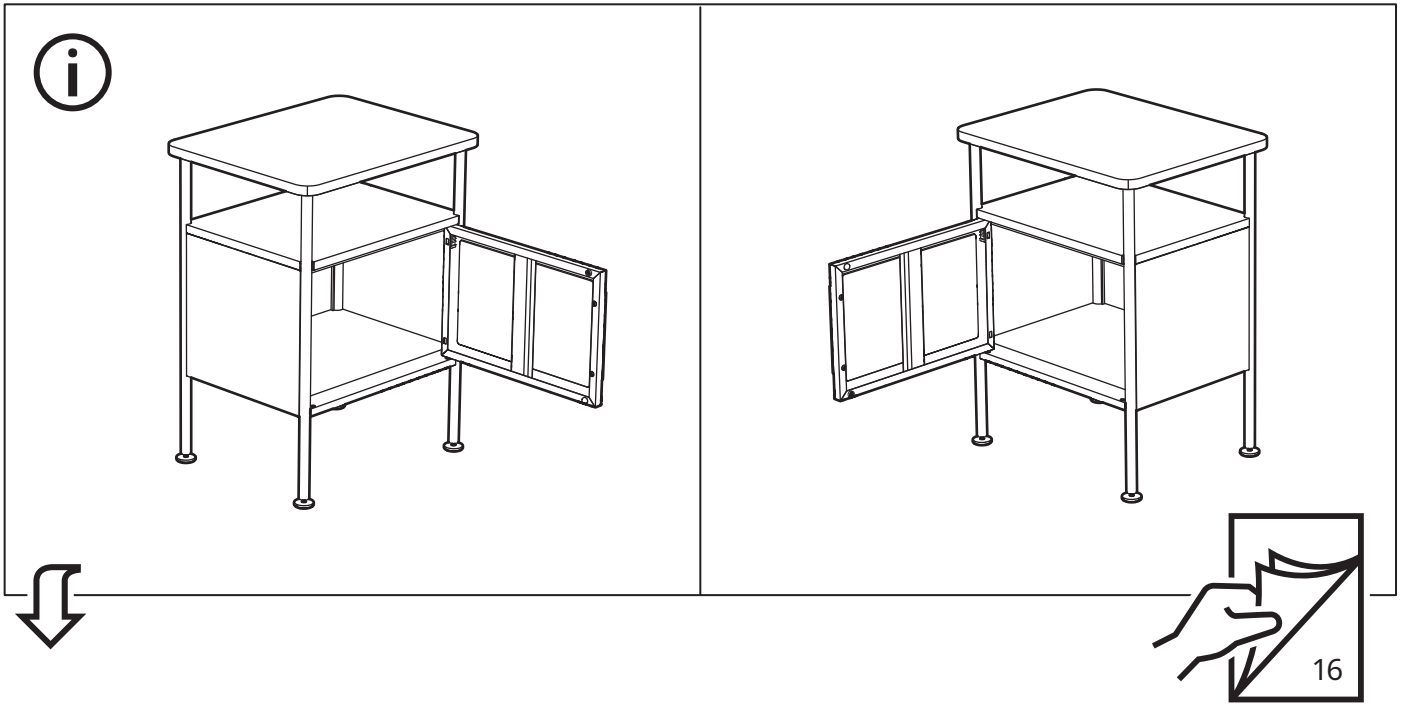

16

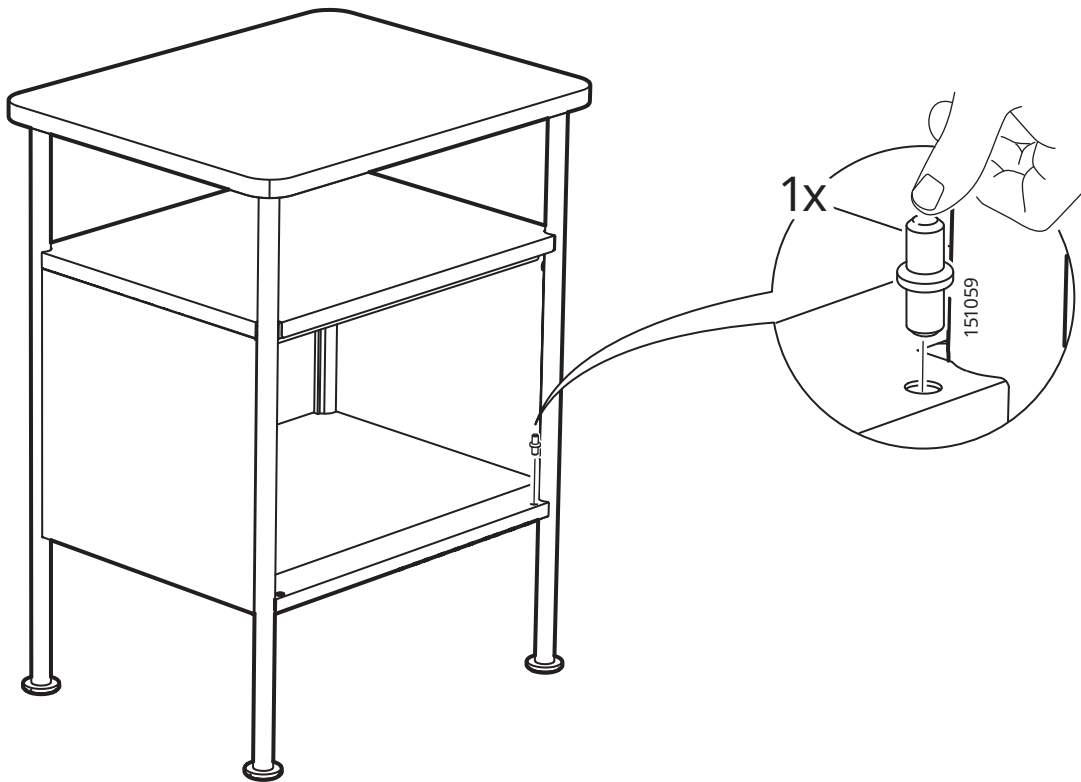

17

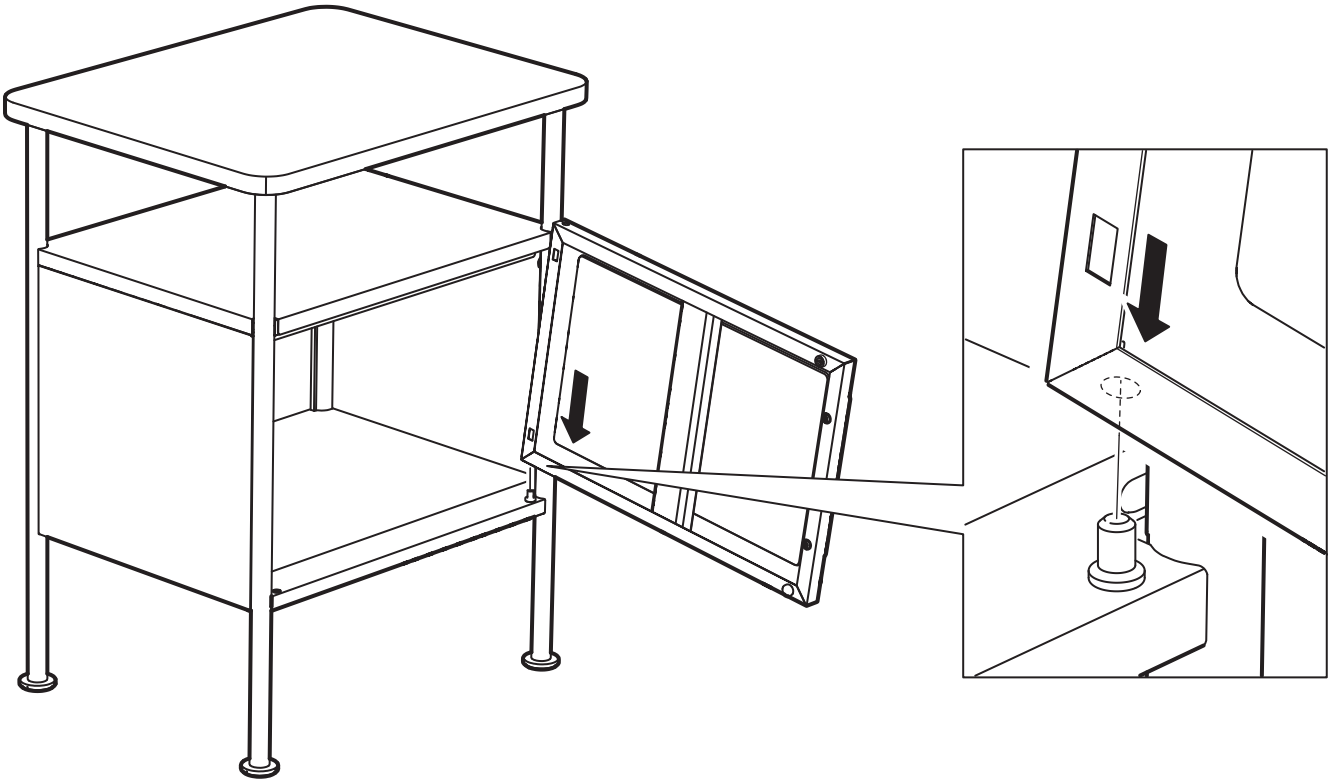

18

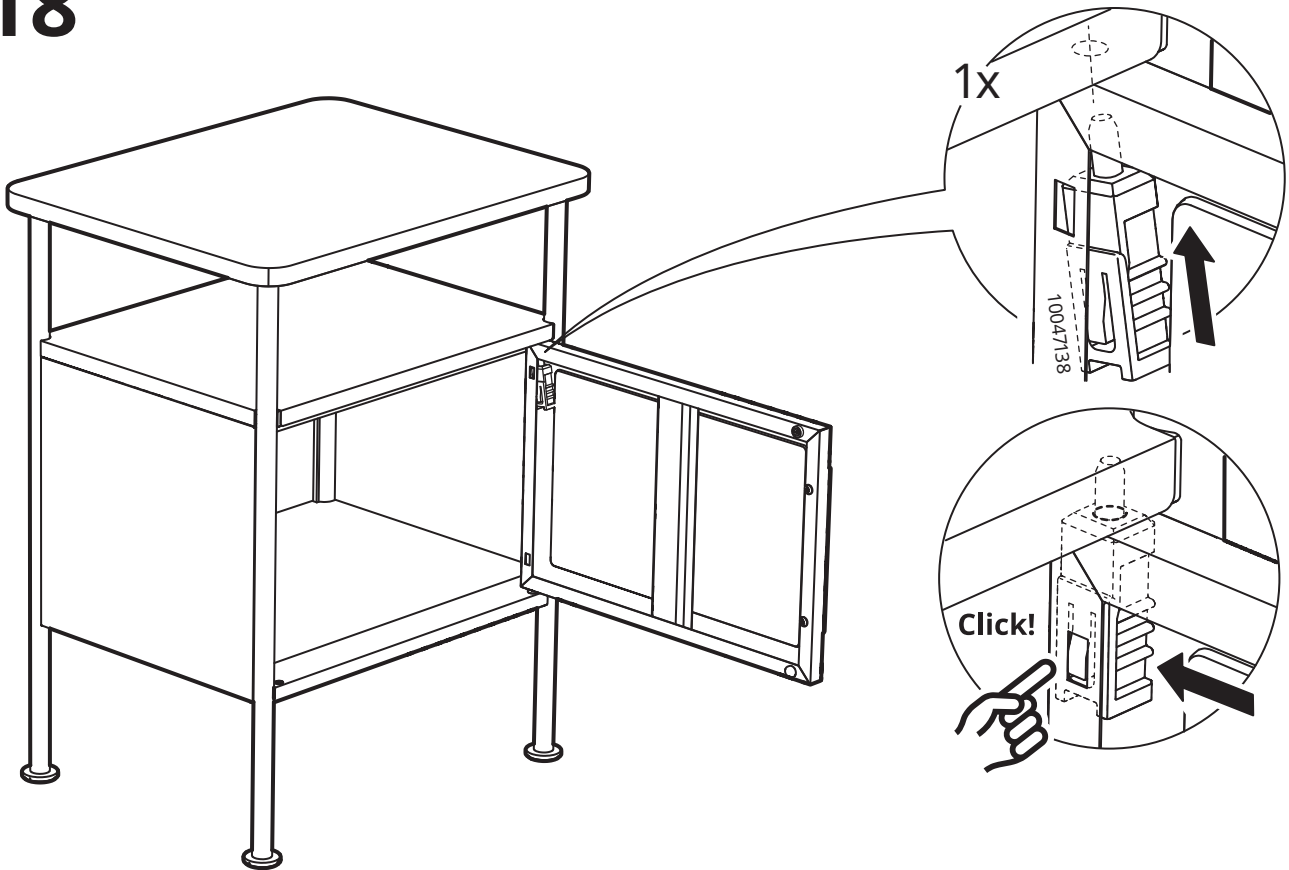

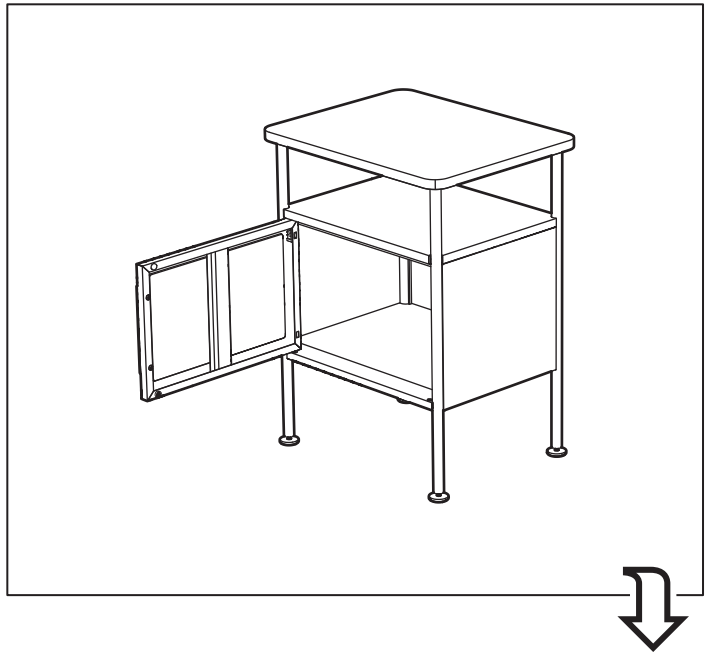

16

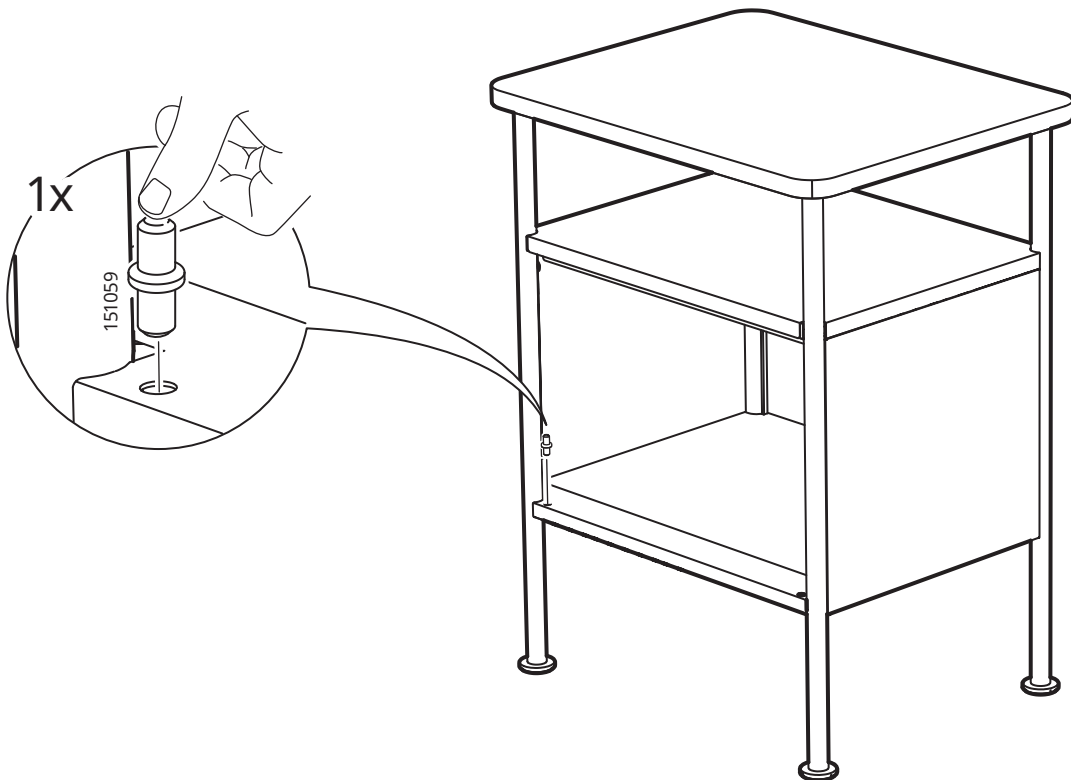



# 17

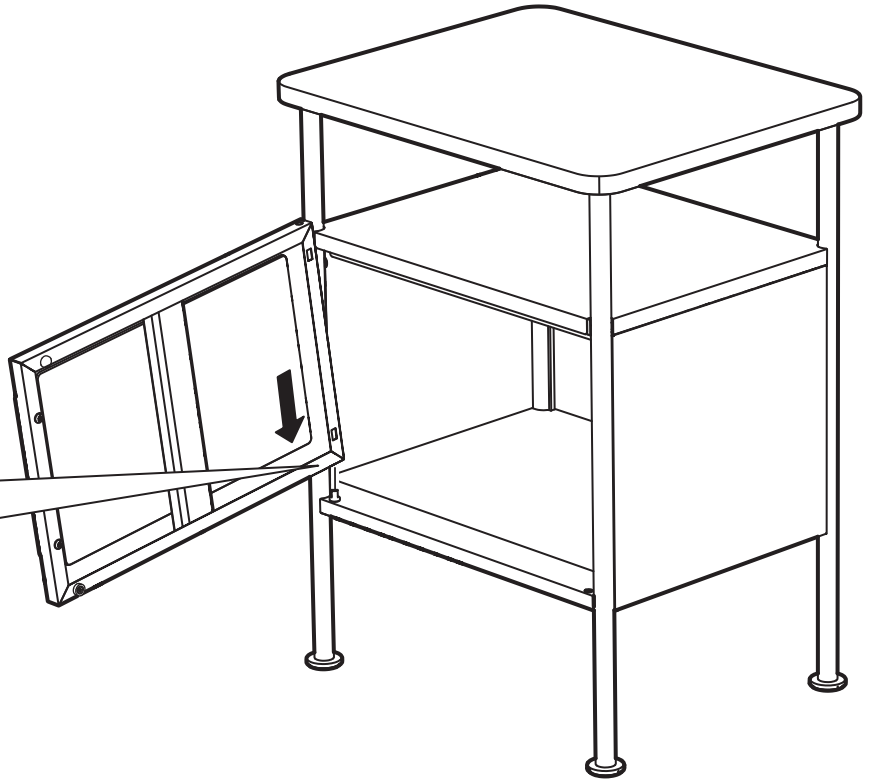
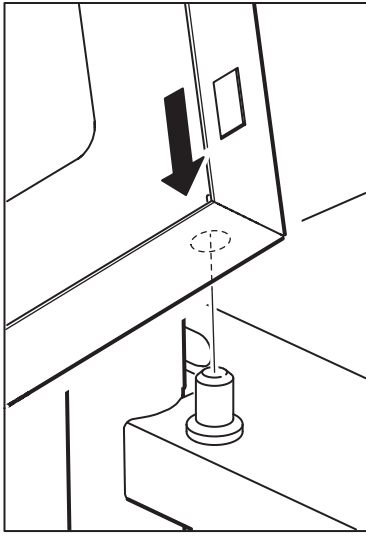

# 18

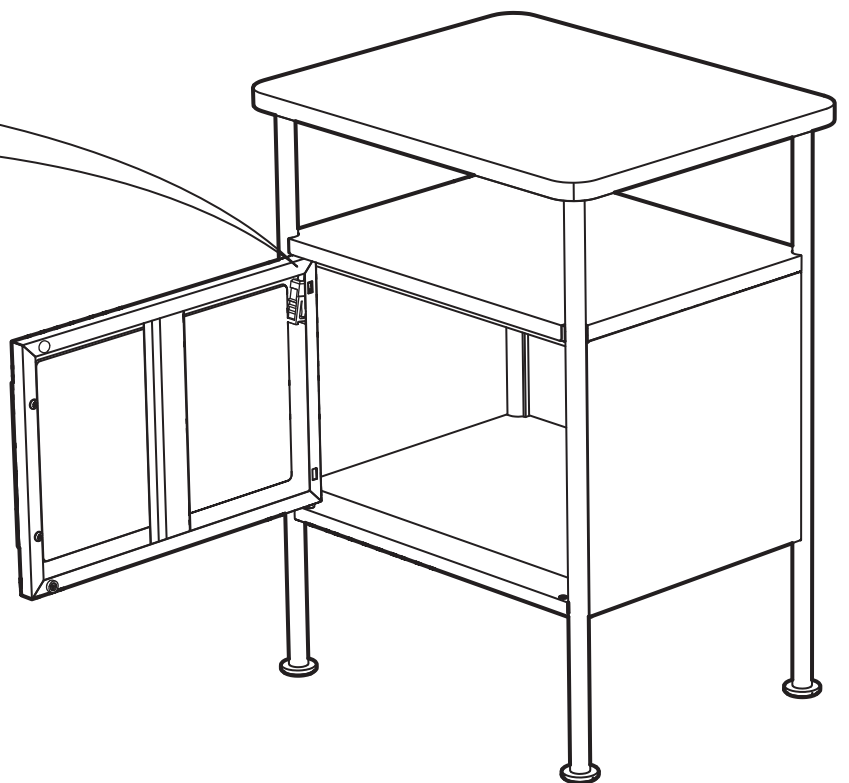
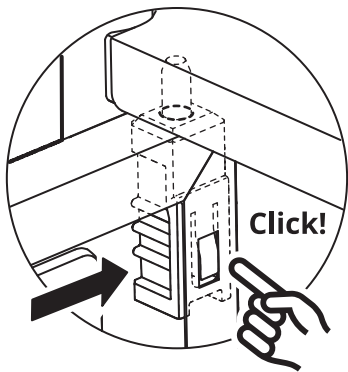
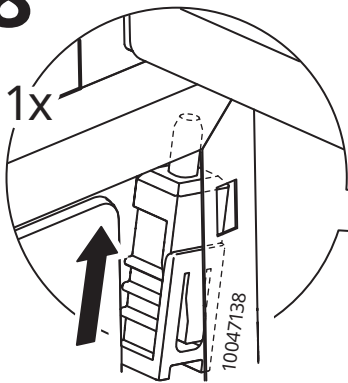

# 19

